

CANDIDATE  
NAME

--

CENTRE  
NUMBER

--	--	--	--	--

CANDIDATE  
NUMBER

--	--	--	--

**MATHEMATICS**

**1112/02**

Paper 2

**October 2015**

**1 hour**

Candidates answer on the Question Paper.

Additional Materials:      Calculator  
   Geometrical instruments  
   Tracing paper (optional)

**READ THESE INSTRUCTIONS FIRST**

Write your Centre number, candidate number and name on all the work you hand in.

Write in dark blue or black pen.

You may use an HB pencil for any diagrams, graphs or rough working.

Do not use staples, paper clips, glue or correction fluid.

DO **NOT** WRITE IN ANY BARCODES.

Answer **all** questions.

Calculator allowed.

You should show all your working in the booklet.

The number of marks is given in brackets [ ] at the end of each question or part question.

The total number of marks for this paper is 50.

This document consists of **19** printed pages and **1** blank page.



- 1 Karim does a survey of the number of people in cars passing his house in the morning. He does this on Monday and on Saturday. The charts show the results.

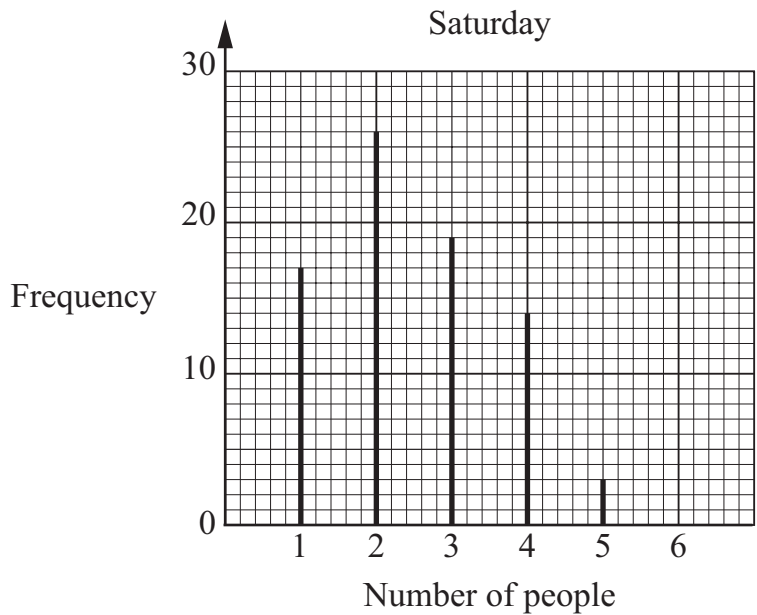
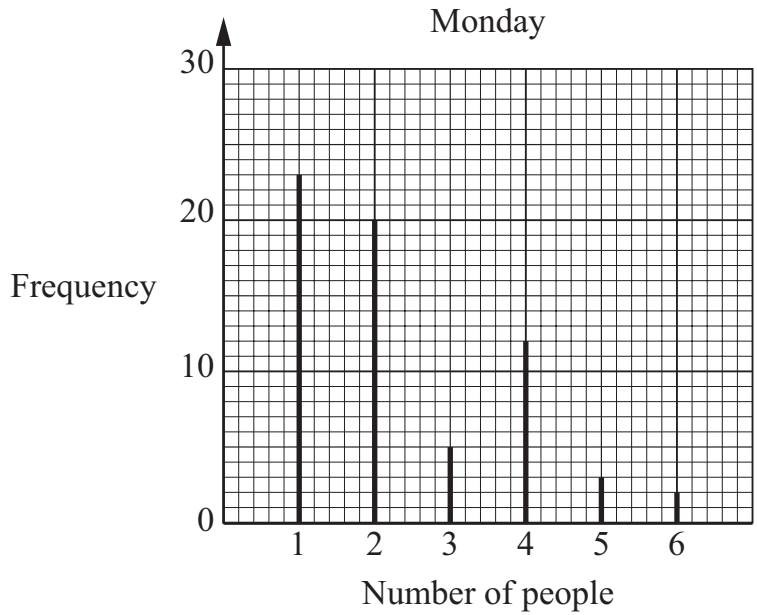

Tick (✓) the box to show which day has the larger mode.

Monday       Saturday       They are the same

Give a reason for your answer.

.....

..... [1]

- 2 Enid uses a term-to-term rule to work out a sequence.  
Here are the first four terms.

23      29      35      41

- (a) Write down the term-to-term rule.

..... [1]

- (b) Work out the 11th term of the sequence.

11th term = ..... [1]

- 3 Rosie is filling up her bath.  
She starts by turning on just the cold tap.  
After a while she also turns on the hot tap.

Put a ring around the graph that best shows the depth of water in Rosie's bath.

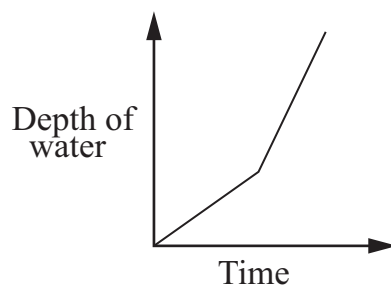
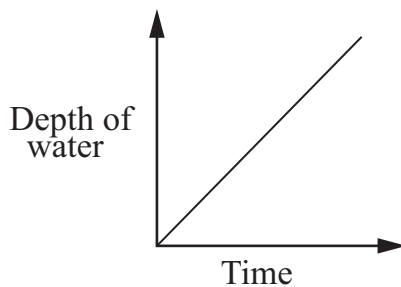
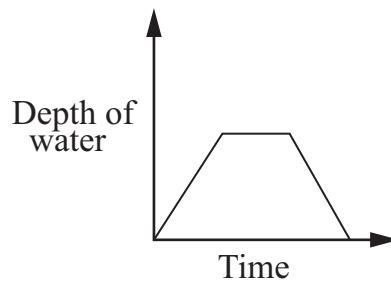
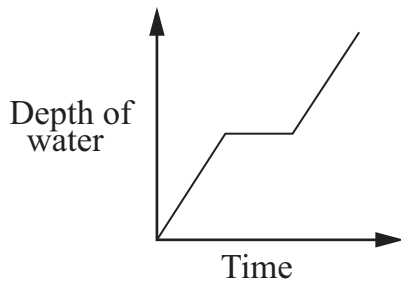

[1]

- 4 The length of a nail rounded to one decimal place is 6.9 cm.

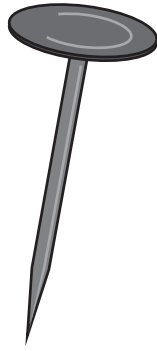

Write down the shortest possible length that the nail could be.

..... cm [1]

- 5 A fruit bowl contains apples, bananas and oranges.  
The number of each type of fruit is shown in the table.

Type of fruit	Number
Apple	2
Banana	6
Orange	4

Tori takes a piece of fruit from the bowl at random.

Draw an arrow to place each of the following events on the probability scale.

- Event E: Tori takes out a banana  
 Event F: Tori takes out an orange  
 Event G: Tori does **not** take out an apple  
 Event H: Tori takes out a strawberry

The first one has been done for you.

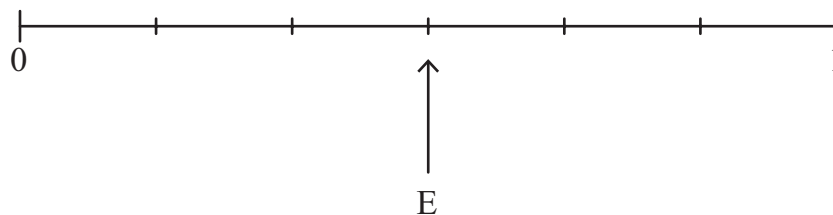

[2]

6 (a) Simplify

$$3y + 7 + 2y + 1$$

..... [1]

(b) Expand the brackets

$$6(2w + 5)$$

..... [1]

7 Amin and Cara take a maths test.  
Amin scores 40 marks and Cara scores 60 marks.

(a) Write the ratio of Amin to Cara's marks as simply as possible.

..... : ..... [1]

(b) They are given \$20 to share between them.  
They share the money in the ratio of their marks.

How much does Amin receive?

\$ ..... [1]

8 This chart shows the time the students in three classes took to complete their homework.

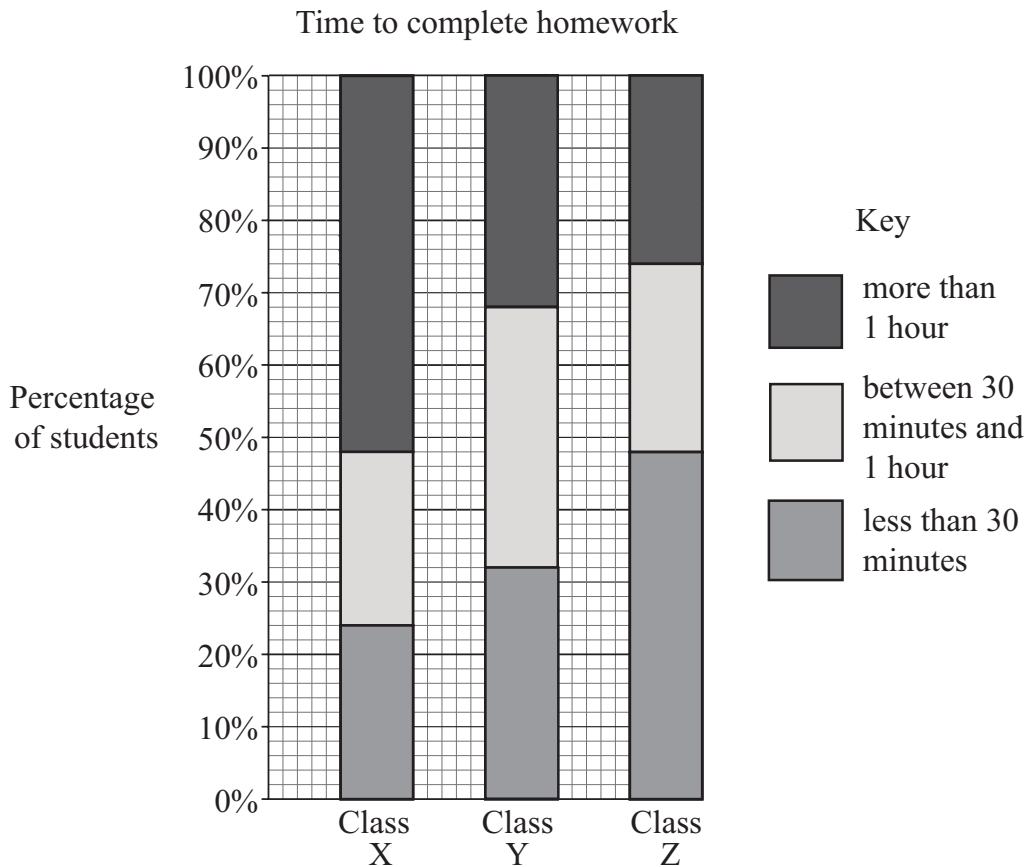

Find the percentage of students in Class X that took more than 1 hour.

.....% [1]

9 Put a ring around the calculation with the largest answer.

$\frac{2}{5}$  of 410

38% of 420

Show how you know.

[2]

10 A circle has a diameter of 8.6 cm.

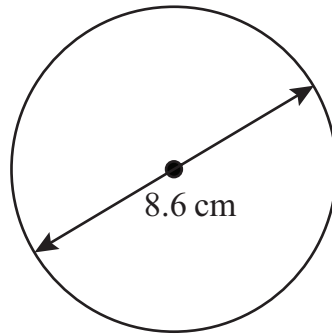

NOT TO  
SCALE

Calculate the circumference of the circle.

..... cm [2]

11 Kofi has 20 snakes.

The lengths in metres of his snakes are

~~1.07~~   ~~0.78~~   ~~1.89~~   2.64   ~~0.55~~   ~~1.43~~   2.51   3.27   2.18   ~~1.79~~  
~~0.63~~   ~~1.12~~   2.07   2.93   ~~1.40~~   3.15   2.83   ~~1.62~~   2.90   ~~1.52~~

- (a) Complete the frequency table for the lengths.  
The first two rows have been done for you.

Length, $l$ (metres)	Tally	Frequency
$0 \leq l < 1$		3
$1 \leq l < 2$		8
$2 \leq l < 3$		
$3 \leq l < 4$		

[1]

- (b) Draw a frequency diagram to show the lengths of Kofi's snakes.  
The first bar has been drawn for you.

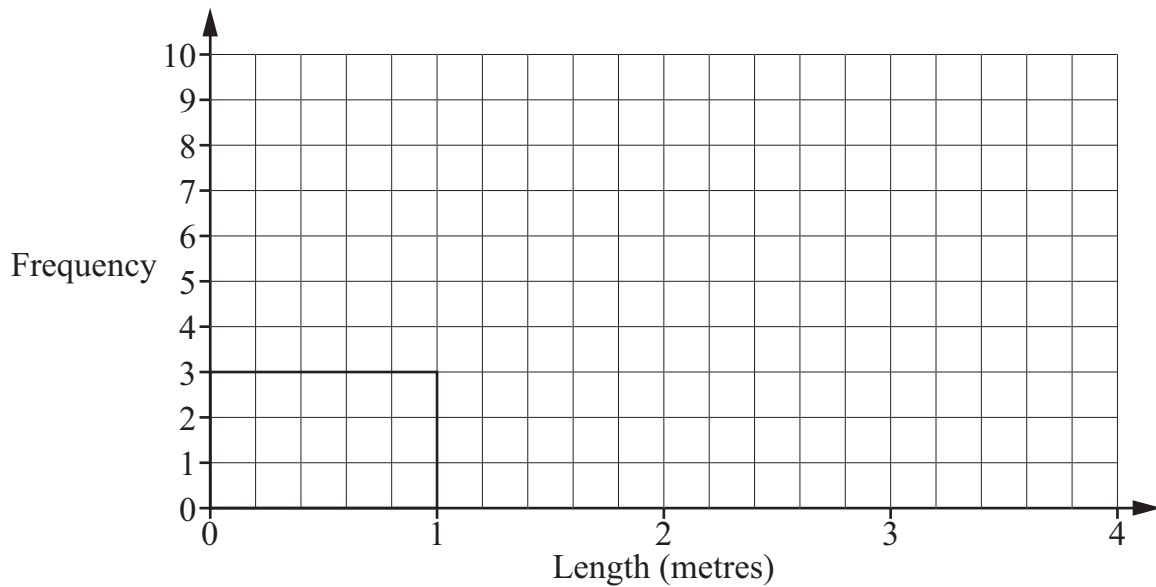

[1]



(c) Liam also keeps snakes.

The lengths of his snakes are shown in the frequency diagram.

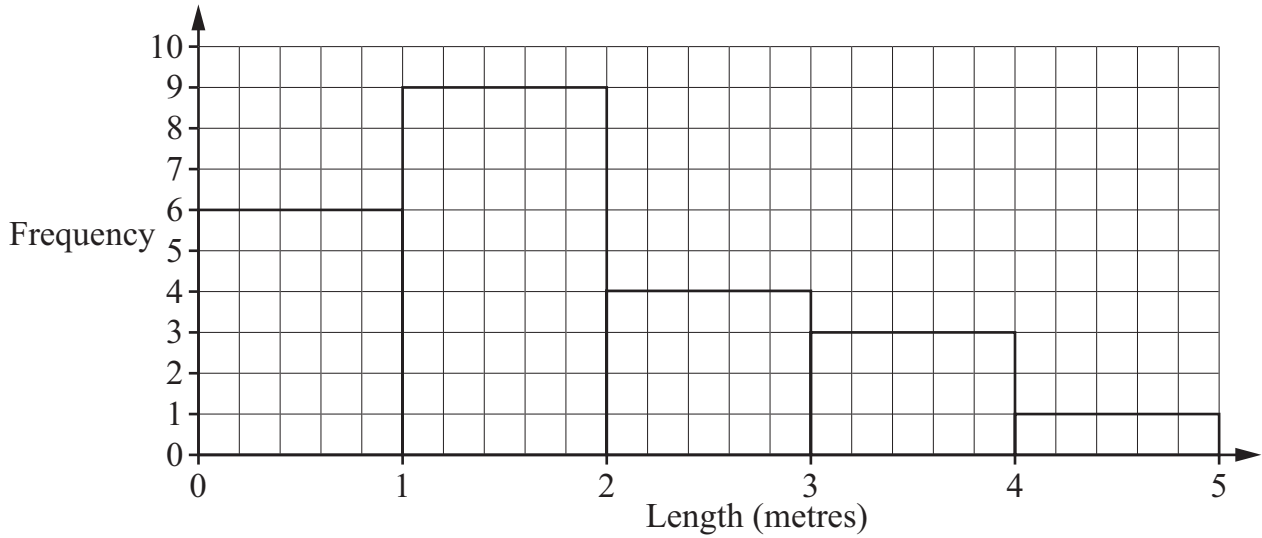

Tick (✓) to show whether each of these statements is true or false.

Liam's longest snake is longer than Kofi's longest snake.

True

False

The modal class for the length of Liam's snakes is the same as the modal class for the length of Kofi's snakes.

True

False

[1]

12 Here are the names of 5 shapes.

- A rectangle
- B pentagon
- C kite
- D parallelogram
- E square

The diagram can be used to sort these shapes.

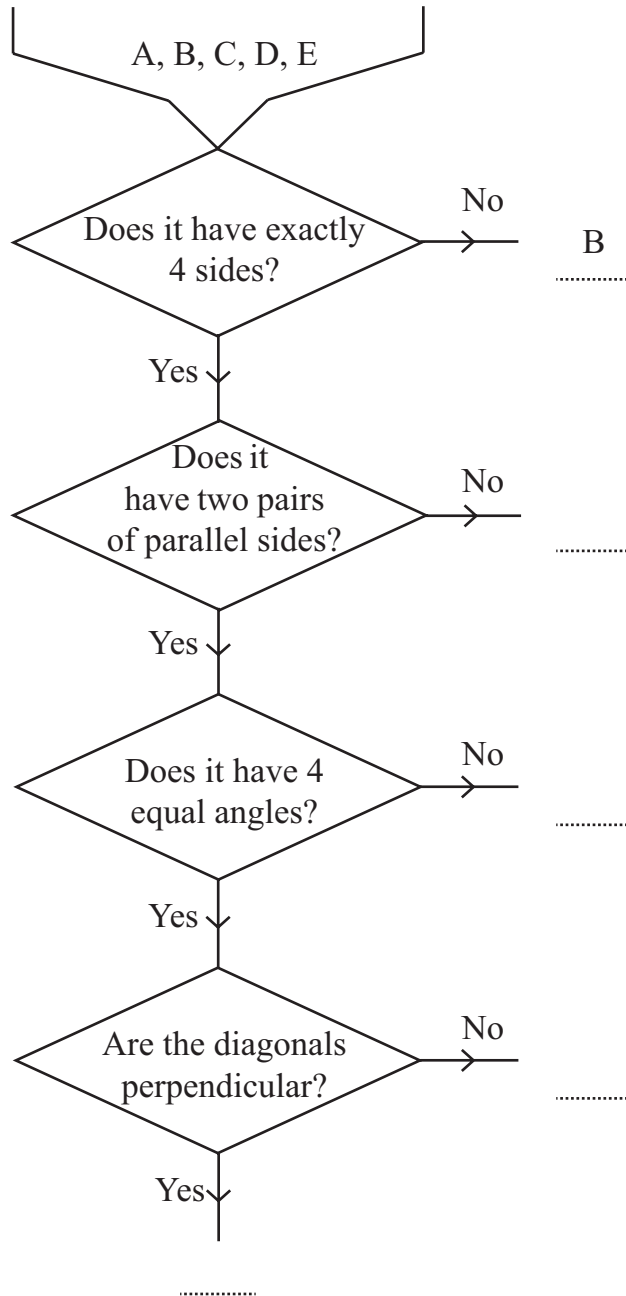

Complete the diagram by writing one of A, B, C, D or E in each gap.  
 B has been done for you.

[2]

13 Jack says,

I think of a number,  $n$ , subtract 5,  
then divide by 7

Write an expression for the result in terms of  $n$ .

..... [1]

14 In a 1.65 hectare area of land, 26% is covered by buildings.

Calculate the area of land, in hectares, covered by buildings.

..... hectares [1]

15  $A$  and  $B$  are points with coordinates  $(-2, 5)$  and  $(6, -7)$ .

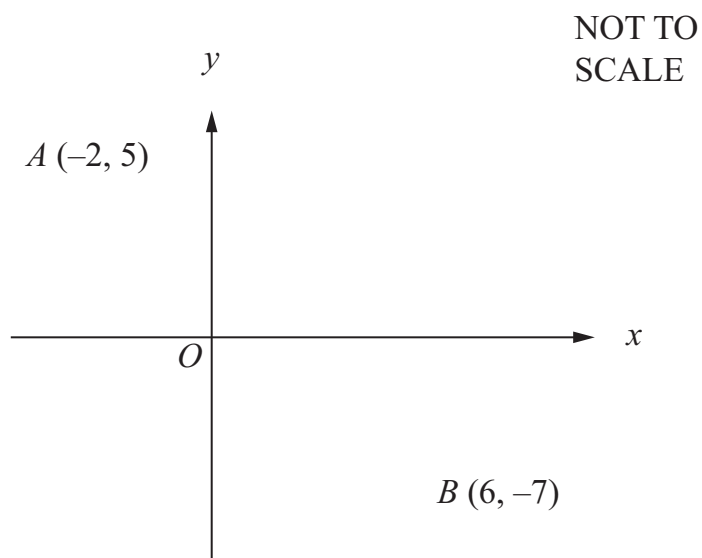

$M$  is the midpoint of the line joining  $A$  to  $B$ .

Work out the coordinates of  $M$ .

( ..... , ..... ) [2]

16 Round each of these numbers correct to 2 significant figures.

$$17865.2 = \text{.....}$$

$$0.006047 = \text{.....}$$

[2]

17 Write as a single power of 3

$$9 \times 3^5$$

..... [1]

18 Calculate the volume of the prism.

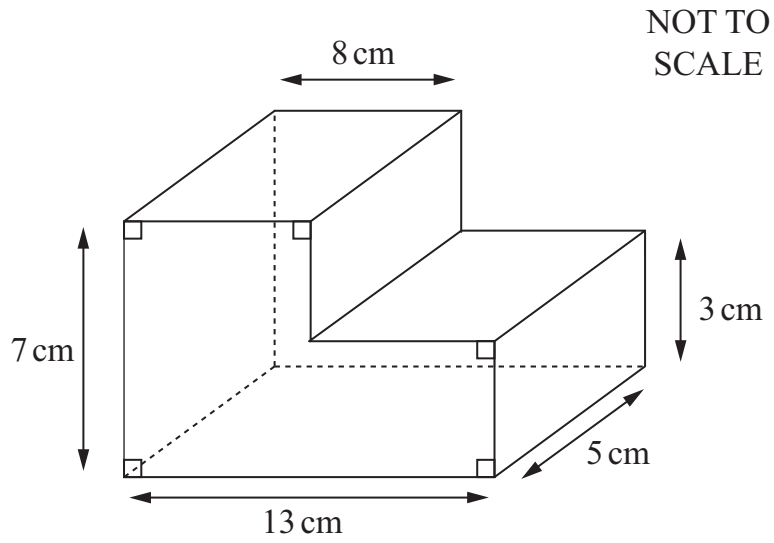

..... cm<sup>3</sup> [3]

19 Write the missing number in the box.

$$40.4 \times 7 = \boxed{\phantom{000}} \times 35$$

[1]

20 The diagram shows three scatter graphs.

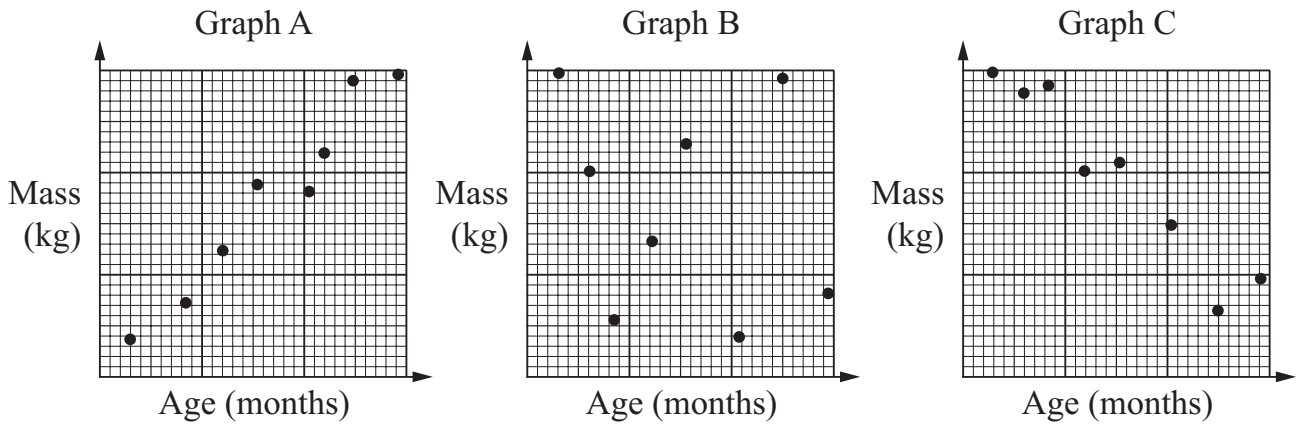

(a) Describe the type of correlation shown in Graph C.

..... correlation [1]

(b) One of the scatter graphs shows the masses of 8 babies plotted against their ages.

Put a ring around this scatter graph.

Graph A

Graph B

Graph C

Give a reason for your answer.

.....  
 ..... [1]

21 Write the missing number in the box.

$$\frac{x}{3} + \frac{x}{\boxed{\phantom{000}}} = \frac{4x}{9}$$

[1]

22 Three containers are shown.



jug

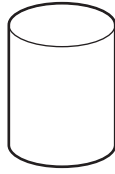

cylinder

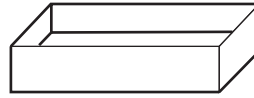

cuboid

The capacity of the jug is 2 litres.

The cylinder has a radius 5 cm and height 15 cm.

The cuboid has width 12 cm, length 15 cm and height 8 cm.

Put the containers in order of their capacities from smallest to largest.  
Show your working.

$\text{Volume of a cylinder} = \pi r^2 h$
---

.....  
Smallest

.....  
Largest

[3]

23 The graph of  $y = x - 3$  is drawn on the grid.

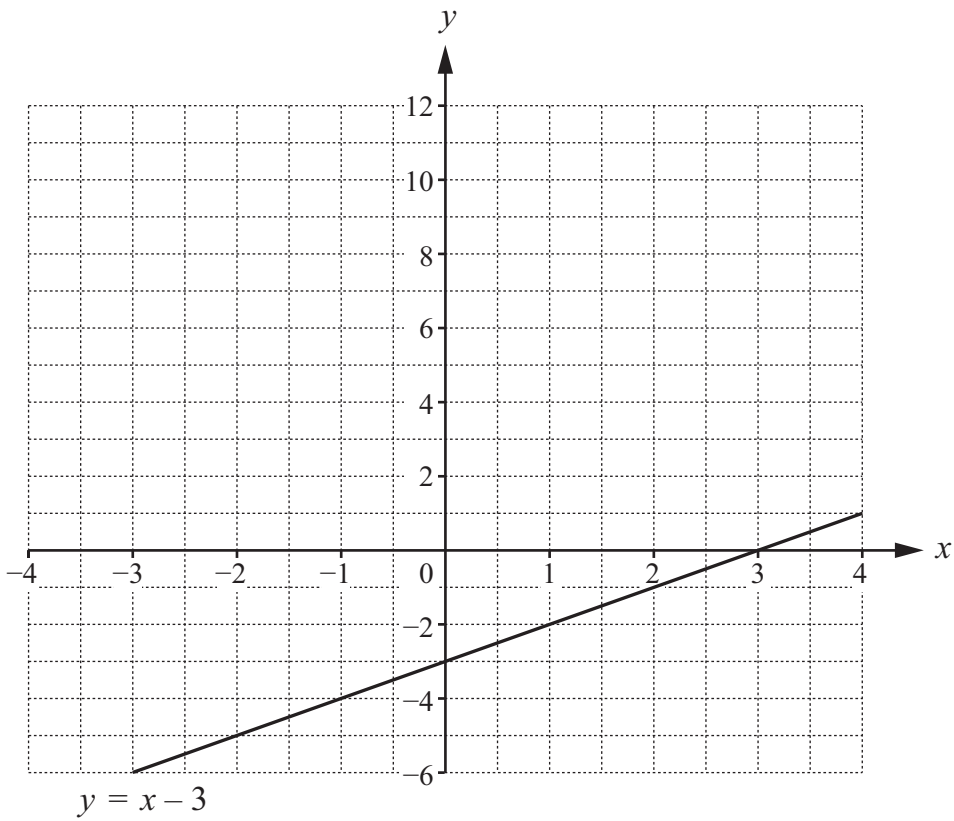

(a) Draw the line  $2x + y = 3$  on the grid.

[2]

(b) Use your answer to part (a) to solve the simultaneous equations.

$$\begin{aligned} y &= x - 3 \\ 2x + y &= 3 \end{aligned}$$

$x =$  .....

$y =$  .....

[1]



- 24 Hari buys 38.5 litres of petrol.  
 He pays \$54.67  
 Josie buys the same type of petrol and pays \$80.00

Calculate how many litres Josie buys.

..... litres [2]

- 25 (a) The probability that a hockey team will draw its next match is 0.1  
 The probability the team will win is twice the probability it will lose.

Work out the probability the team will win.

..... [1]

- (b) This table shows the results of two handball teams in recent matches.

	Win	Lose	Draw
Team A	7	5	4
Team B	9	12	7

Which team has a better winning record?  
 Put a tick (✓) in the correct box.

Team A                       Team B                       Both the same

Give a reason for your answer.

.....  
 ..... [1]

26 The diagram shows the positions of a bridge, a tower and a station.

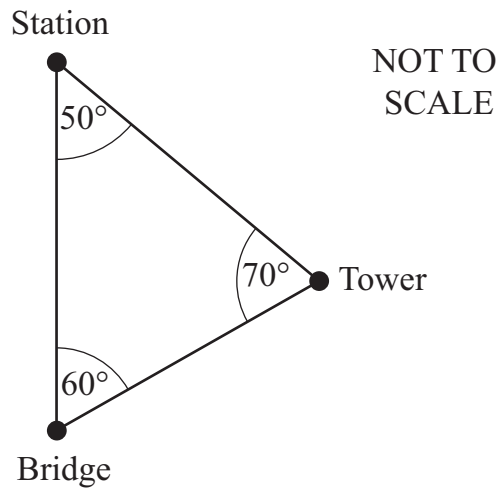

The station is due north of the bridge.

(a) Write down the bearing of the tower from the bridge.

Bearing = .....<sup>o</sup> [1]

(b) Work out the bearing of the station from the tower.

Bearing = .....<sup>o</sup> [1]

27 Nadia is organising a party.  
 She wants to buy 18 litres of orange juice.  
 She can buy it from her local shop or from the supermarket.

Local shop

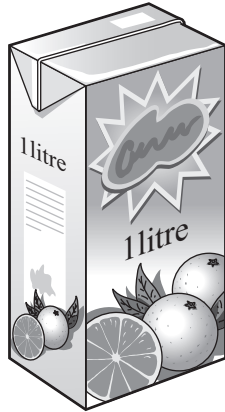

\$2.48

Supermarket

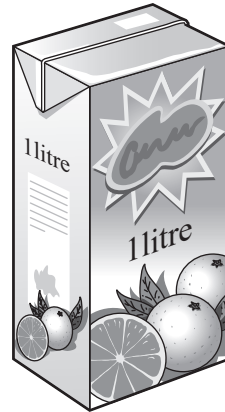

\$2.10

Her local shop offers her a discount of 12.5% off the total price if she buys 12 or more cartons.

She wants to buy the orange juice from just one shop.

Work out which shop is cheaper, and by how much.

..... is cheaper by \$ ..... [3]

**BLANK PAGE**

---

Permission to reproduce items where third-party owned material protected by copyright is included has been sought and cleared where possible. Every reasonable effort has been made by the publisher (UCLES) to trace copyright holders, but if any items requiring clearance have unwittingly been included, the publisher will be pleased to make amends at the earliest possible opportunity.

Cambridge International Examinations is part of the Cambridge Assessment Group. Cambridge Assessment is the brand name of University of Cambridge Local Examinations Syndicate (UCLES), which is itself a department of the University of Cambridge.